

- Stepper motor technology with 24 V DC drive
- Different metering capacities selectable via jumper:
 - Standard 1.0 to 20 l/h
 - High viscosity 1.0 to 15 l/h
 - Reduced metering rate 0.1 to 2.6 l/h
- Short suction stroke and long metering stroke configurable
- Infinitely metering volume setting in range 1:50
- Nearly pulsation-free metering possible
- Various intake speeds selectable, depending on the product viscosity
- Space-saving manifold assembly possible thanks to lean design

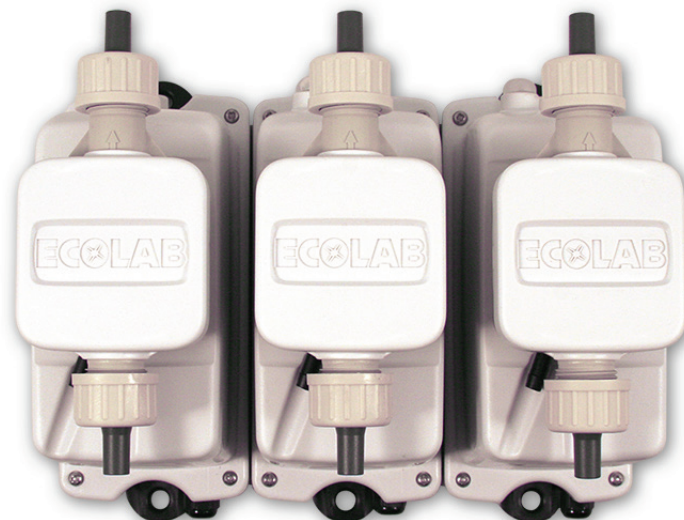

The TurboSmartPump II is the consistently enhanced version of a tried-and-trusted Ecolab pump. For example, improvements such as externally accessible metering volume settings, a metering stroke indicator, and optimised setting accuracy in the lower dispensing range have been implemented.

Thanks to the new housing concept with frontal arrangement of the pump head, the design is extremely compact. Using the U-connector included in the scope of supply, several pumps can be mounted, thus saving space in the array.



Technical Data:

General:

Pump capacities: - Standard - High viscosity - Reduced metering rate	infinitely variable from 1.0 to 20 l/h 1.0 to 15 l/h 0.1 to 2.6 l/h
Max. metering back-pressure:	0.2 MPa (2 bar)
Max. suction height:	1.5 m Ws
Ambient temperature:	15° – 40° C
Hose connection:	G 5/8
Power supply:	24 V DC 240 V, 50/60 Hz (option)
Safety class:	IP 52
Weight:	approx. 1.3 kg

All values at 50 Hz. All data refer to water temperature of 20° C according to the instructions of the technical manual, subject to!

Material:

Component	Pump Type	
	EPDM version	FPM version
Housing:	ABS cover, PPE (Noryl) back board	
Pump head:	PP	
Diaphragm:	EPDM / PTFE	
Valve body:	PP	
Valve balls:	Ceramics	
Seals:	EPDM	FPM
Colour:	Cover: Ecolab grey, back board: black	

Dimensions:

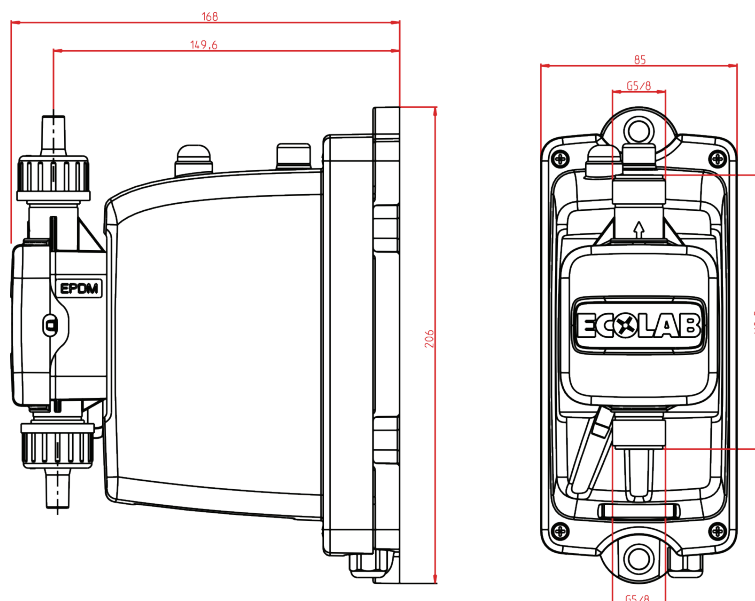

**Ordering Data:**

Article	Version	Material-No.
TurboSmartPump II	20 l/h PP-EPDM-24V DC	106052
	20 l/h PP-FPM-24V DC	106064
Extent of supply:	Fixing material for wall mounting, U-connector for manifold assembly, operating instruction	



Accessories:

Article

Material-No.



Hose

PVC-fabric di10x3 (10/16 mm)
available by the metre

417400126

Note: We explicitly point out that PVC fabric tubes have a limited lifetime if alkaline chemicals will be used. To avoid damage for your staff and your company the tubes have to be exchanged at least every 6 months. In case of non-compliance we exclude all kinds of liability and responsibility.



Bottom admission valve

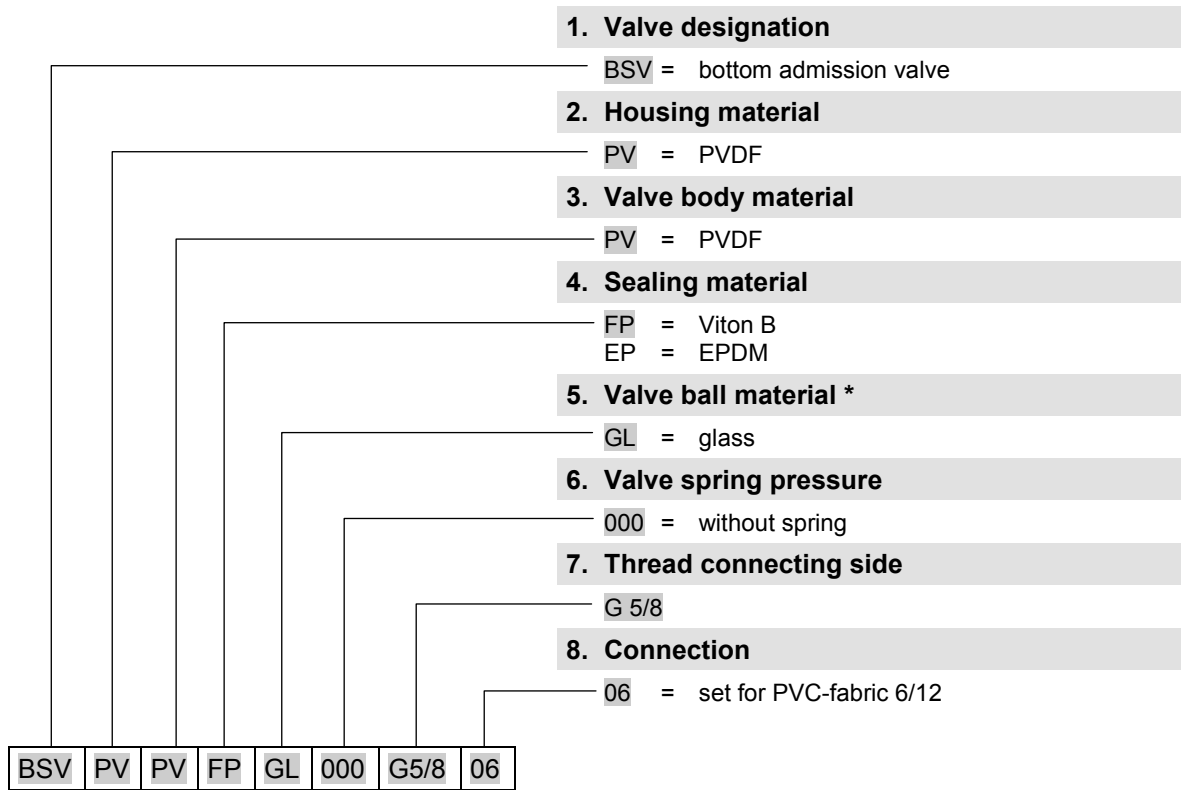

Article

Material-No.

BSV PV PV FP GL 000 G 5/8 – 06

249018

BSV PV PV EP GL 000 G 5/8 – 06

249024

Connection material for hose 10/16 mm:



Tapered part

38610415

PVDF for inner Ø 10 - 5/8"



Clamping piece

38610409

1.4571 for outer Ø 16 - 5/8"

Union nut

included in delivery of bottom admission valve



Metering valves

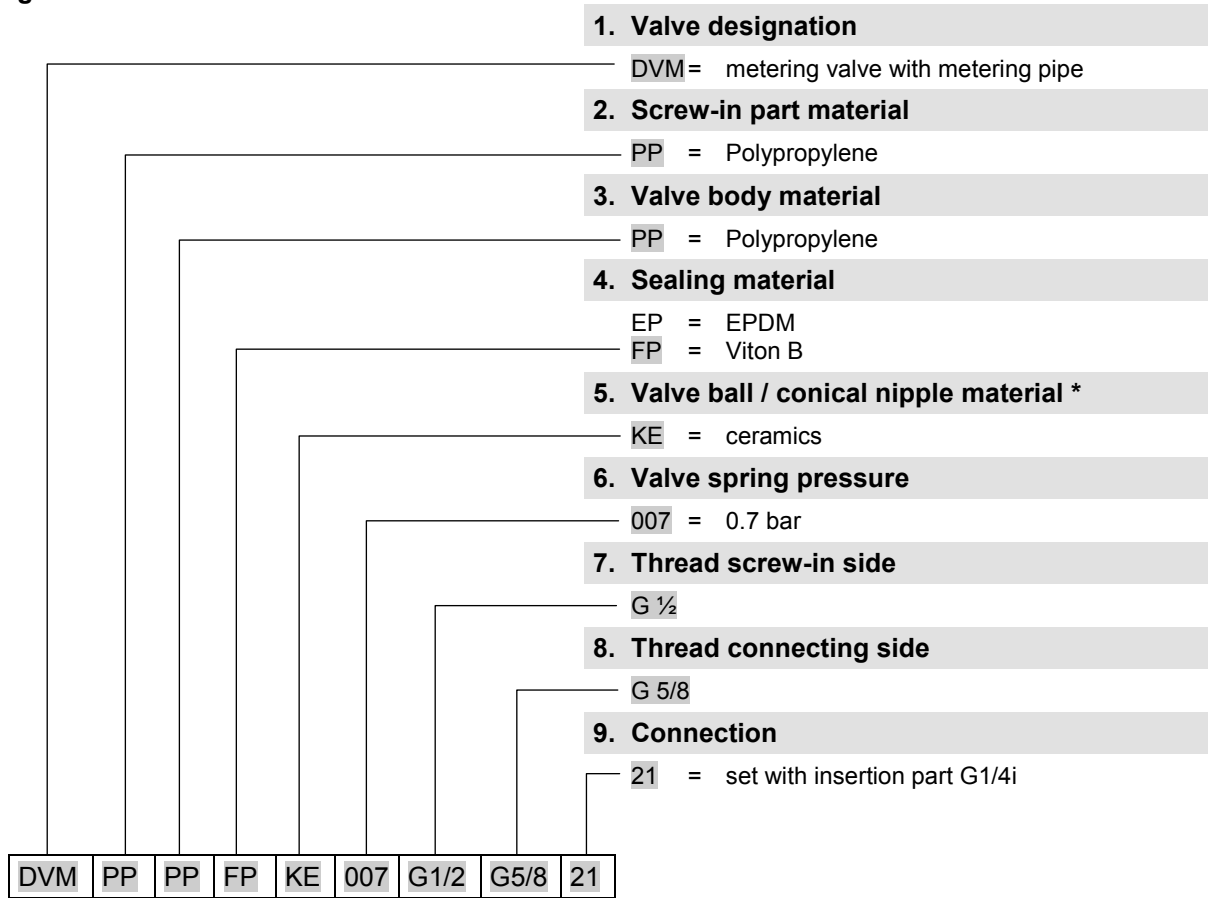

Article

Material-No.

DVM PP PP FP KE G 1/2 – G 5/8 – 21	245040
DVM PP PP EP KE G 1/2 – G 5/8 – 21	245041

Connection material for hose 10/16 mm:



Tapered part

38610416

PP for inner Ø 10 - 5/8"



Clamping piece

38610409

1.4571 for outer Ø 16 - 5/8"

Union nut

included in delivery of bottom admission valve



Spare Parts:



Article

Material-No.

Pump head complete

Pump head 15 l/h PPEPKE 206001

Pump head 15 l/h PFPKE 206002

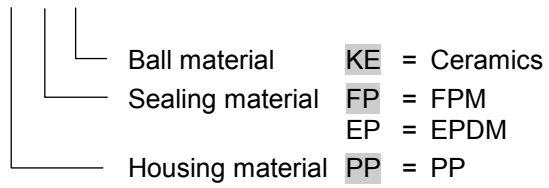

Connection set

249237

Connection set PP G 5/8 - 6/12, 10/16 mm



Diaphragm

30601023

Diaphragm 15 l/h EPDM / PTFE